



Pitch:3.5/3.81mm

MODEL:JL350B

认证/CERTIFICATION



材质及电镀

螺丝	M2.0, 钢, 镀锌
方块	磷青铜, 镀镍
焊脚	黄铜, 镀锡
塑件	PA66, UL94V-0

电气性能

参考标准	UL	IEC
额定电压	300V	250V
额定电流	10A	13.5A
使用线径	30-16 AWG	1mm ²
接触电阻	20mΩ	
绝缘电阻	500MΩ/DC500V	
耐电压	AC2000V/1Min	

机械性能

温度范围	-40°C~+105°C
瞬时温度	+250°C 5秒
扭矩	2.04kgf-cm/0.2Nm/1.77Lbin
剥线长度	5-6mm

MATERIAL

Screws	M2.0 Steel Zn plated
Cage	Phosphor bronze, Ni plated
Pin header	Brass, Sn plated
Housing	PA66, UL94V-0

ELECTRICAL

Standard	UL	IEC
Rated voltage	300V	250V
Rated current	10A	13.5A
Wire range	30-16 AWG	1mm ²
Contact resistance	20mΩ	
Insulation resistance	500MΩ/DC500V	
Withstanding voltage	AC2000V/1Min	

MECHANICAL

Temp. range	-40°C~+105°C
Max. soldering	+250°C 5 Sec
Torque	2.04kgf-cm/0.2Nm/1.77Lbin
Strip length	5-6mm

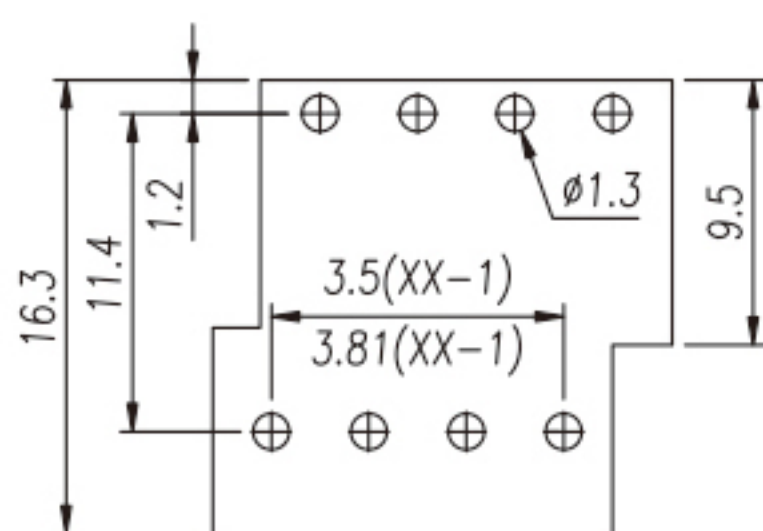

P.C.B. LAYOUT

